

B-Series

Commercial Evaporators



- Coil with optimised 3/8" Rife bore tube
- White powder coated aluminium casing
- Patton Coat coil & fin corrosion protection
- High airflow external axial fan motors
- Optional with EC fan motor assemblies
- Models available with EVD ice + UltraCap
- Defrost heater termination/safety klixon
- Ideal for Coolrooms & Freezer Rooms

B SERIES



MEDIUM TEMP

MODELS	BM	15	19	22	26	32	37	44	52	57	62	66	76	86
Capacity Watts -4 SST / 6 KTD	R404A	1530	1920	2250	2610	3090	3750	4410	5250	5760	6210	6690	7710	9000
	R448A	1480	1860	2180	2530	3000	3640	4280	5090	5590	6020	6490	7480	8730
	R134a	1380	1740	2040	2370	2790	3420	3990	4770	5250	5640	6090	7020	8190

LOW TEMP

MODELS	BL	14	20	27	38	42	49	56
Capacity Watts -24 SST / 6 KTD	R404A	1410	1980	2820	3930	4260	4920	5700
	R448A	1350	1900	2710	3770	4090	4720	5470

■ R448A listed ratings have been calculated at 'mid point' conditions.

TECHNICAL DATA

MEDIUM TEMP

MODELS	BM	15	19	22	26	32	37	44	52	57	62	66	76	86	
Air Throw	m	8.0	7.0	7.0	8.0	8.0	10.0	10.0	11.0	12.5	12.0	13.0	14.0	13.5	
Air Volume	l/sec	450	420	410	480	460	840	820	960	1260	1230	1300	1680	1630	
Fan Motors	Ø 300mm	Num.	1	1	1	1	2	2	2	3	3	3	4	4	
		Watts	60	60	60	60	60	120	120	120	180	180	180	240	240
		Amps	0.3	0.3	0.3	0.3	0.3	0.6	0.6	0.6	0.9	0.9	0.9	1.2	1.2
Coil	Circuit Vol.	dm3	0.68	1.36	1.36	2.04	2.04	2.71	2.71	4.08	4.08	4.08	5.44	5.44	
	Connection	Dist Inlet	1/2"	1/2"	1/2"	1/2"	1/2"	1/2"	1/2"	1/2"	1/2"	1/2"	1/2"	1/2"	
	F.Sw	Suct Outlet	1/2"	1/2"	1/2"	5/8"	5/8"	3/4"	3/4"	3/4"	3/4"	3/4"	7/8"	7/8"	
	fpi		8	6	8	6	8	6	8	6	6	8	6	6	
Dimensions	(mm)	L	606	606	606	797	797	988	988	1370	1370	1370	1752	1752	
		A	412	412	412	603	603	794	794	1176	1176	1176	1558	1558	
Net Weight	kg	11	12	12	15	15	21	21	26	29	30	35	38	40	

LOW TEMP

MODELS	BL	14	20	27	38	42	49	56	
Air Throw	m	6.5	8.0	9.0	10.0	11.5	12.0	13.0	
Air Volume	l/sec	420	480	840	960	1260	1300	1680	
Fan Motors	Ø 300mm	Num.	1	1	2	2	3	3	
		Watts	60	60	120	120	180	180	240
		Amps	0.3	0.3	0.6	0.6	0.9	0.9	1.2
Coil	Circuit Vol.	dm3	0.68	2.04	2.71	4.08	4.08	5.44	
	Connection	Dist Inlet	1/2"	1/2"	1/2"	1/2"	1/2"	1/2"	
	F.Sw	Suct Outlet	1/2"	5/8"	3/4"	3/4"	3/4"	7/8"	
	fpi		6	6	6	6	6	6	
Defrost	Watts	1360	1700	2380	2960	2960	4060	4060	
	Amps	5.9	7.4	10.3	12.9	12.9	17.7	17.7	
Dimensions	(mm)	L	606	797	988	1370	1370	1752	
		A	412	603	794	1176	1176	1558	
Net Weight	kg	14	18	24	31	34	41	44	

- All B-Series evaporators require externally equalised expansion valves.

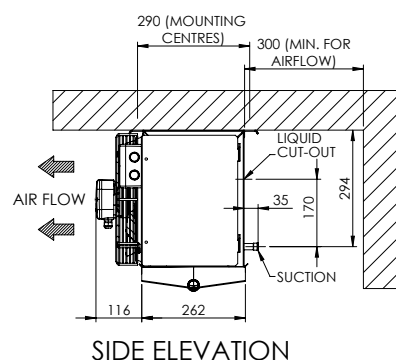
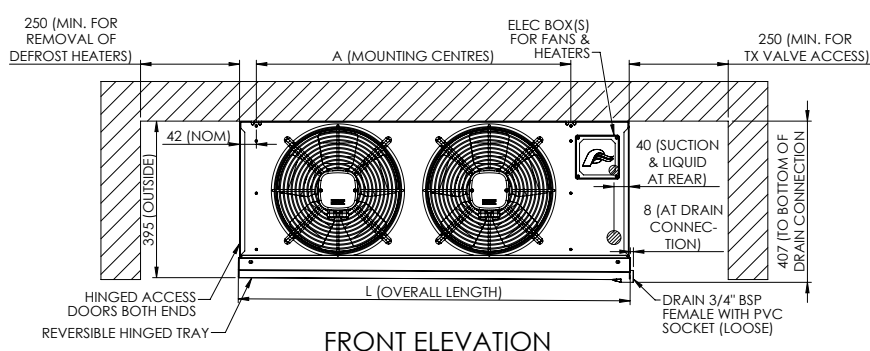

RELATIVE HUMIDITY GUIDE (MED TEMP)

Temp Diff	R.H %
4K	89
6K	84
8K	81
10K	77

CAPACITY CORRECTION GUIDE

BM @ SST		BL @ SST	
+5	1.17	-20	1.07
0	1.07	-25	0.99
-5	0.99	-30	0.89
-10	0.93	-35	0.80

Specifications subject to change without notice

NOTES

- All fan motors 220-240V/1/50Hz
- Defrost heaters 220-240V/1/50Hz
- Defrost klixon contacts open +24°C / close +5°C
- Air throw based on CRMA standard @ 20°C
Multiply figures by 0.94 for 2°C or 0.87 for -18°C